

Various Bolt Removal Process'

Introduction

I have been climbing close to 30 years. The first bolt I placed in 1987 was a 5/16" Rawls™ carbon steel, split shank, button head in sandstone. Certainly the wrong bolt, but was testing it out for granite on the first route I would put up on lead in the Wichita Mountains Wildlife Refuge in 1988.

I returned to putting up routes in 2007. This time with history in the knowledge bank of how the climbing community was replacing 1/4" bolts put in prior to the mid 80's and then 5/16" bolts put in during the late 80's then the standard becoming 3/8" bolts in the 90's, I was determined to do it right. As you can see the bolt size continued to increase over the years as more studies came in as to what was really required for strength.

The climbing community continues to place carbon steel bolts and hangers that rust, thus facility constant maintenance. We as climbers and stewards of the rock should be placing SS bolts. Even though the initial investment is more, it saves the rock and work in the years to come.

I have a source for purchasing Powers bolts at a great price that I would like to share.

<http://www.fastenmsc.com/p-99691-power-bolt-hex-head-12-x-4-34-stainless-steel-5934-25.aspx>

<http://www.fastenmsc.com/p-99688-power-bolt-hex-head-38-x-3-12-stainless-steel-5914-50.aspx>

<http://www.fastenmsc.com/p-99687-power-bolt-hex-head-38-x-2-14-stainless-steel-591050.aspx>

The bolts I started placing in 2007 were 3/8" x 3 3/4" Fixe™ double wedge SS in sandstone. The next year I then bumped the size up to be 1/2" x 4 3/4" Powers™ SS bolts. The change was made for a couple of reasons; first sandstones low strength just warranted a larger and deeper bolt, second; I wanted a bolt that could be replaced only leaving the original hole that was drilled. One other positive reason is if something isn't working correctly at installation the bolt can easily be removed to correct the problem.

I have thought about getting this document together for a couple of years. Not until I was reading some posts on www.summitpost.com was I motivated to help the climbing community to replace bolts in a less destructive manner.

Gary Ballard (updated 15Dec2014)

Tools for Powers™ 5 Piece Bolt Removal Process

Required tools for 3/8" Powers™ bolt removal:

- A. 1) 1/2" box or open end wrench for cone extraction tool and original bolt removal
- B. Sleeve Extraction Tool (see drawing)
- C. 1) 7/64" T-handle hex wrench (modified)
- D. Tap Handle
- E. 9mm X 1 Tap
- F. 3/4" Box or open end wrench for Sleeve Extraction Tool Hx. Hd.
- G. Expansion Cone Extraction Tool
 - a. 5/16-18UNC 5 inch long, full thread, Grade 8 Hex. Hd. Cap Screw. McMaster Carr p/n [92620A599](#)
 - b. 5/16-18UNC coupling nut. McMaster Carr p/n [90977A150](#)
 - c. 5/16 i.d. x thick washer (use washer from Powers™ bolt)
- H. 5/16" O.D. x 15" long blow hose
- I. 3/8" Hole brush

Optional tools

- A. 5/16-18 tap x 6" long (optional)
- B. Vice Grip™, needle nose pliers
- C. Magnet to reach to the expansion cone

Required tools for 1/2" Powers™ bolt removal:

- A. 5/8" box or open end wrench
- B. Sleeve Extraction Tool
- C. 9/64" T-handle hex wrench (modified)
- D. Tap Handle
- E. 11mm x 1.5 tap
- F. 3/4" Box or open end wrench for Sleeve Extraction Tool Hx. Hd.
- G. Expansion Cone Extraction Tool
 - a. 1) 3/8-16UNC x 1 ft. long piece of all-thread
 - b. 1) 3/8-16UNC long nut (regular nut will strip on all-thread)
 - c. 1) 3/8 i.d. x thick washer (use washer from bolt)
- H. 3/8" O.d. x 18" long blow hose
- I. 1/2" Hole Brush

Optional tools

- A. 3/8-16 tap x 6" long (optional)
- B. Vice Grip™, needle nose pliers
- C. Magnet to reach to the expansion cone

T-handle hex wrench modification

Place 3/8" to a 1/2" of the hex end of the wrench into the jaws (smooth side of jaws). The handle of the wrench is up and almost parallel with the vice-jaws. The flat of the hex is not parallel with the handle so the misalignment occurs.

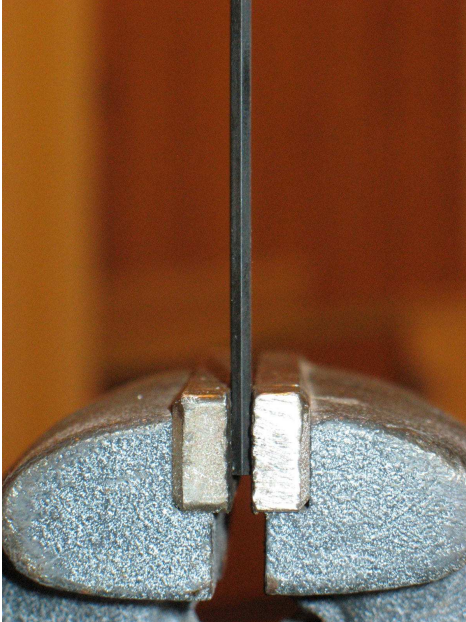

With an oxy-acetylene or propane torch, (I used a gas grill lighter) heat the hex wrench at the bend area. When the wrench gets orange to almost red at the bend area; start to bend the tip down to 90°. I hammered on the bend some as I bent it to attempt to make the bend tighter. When you are satisfied with the bend remove from the vice and cool.



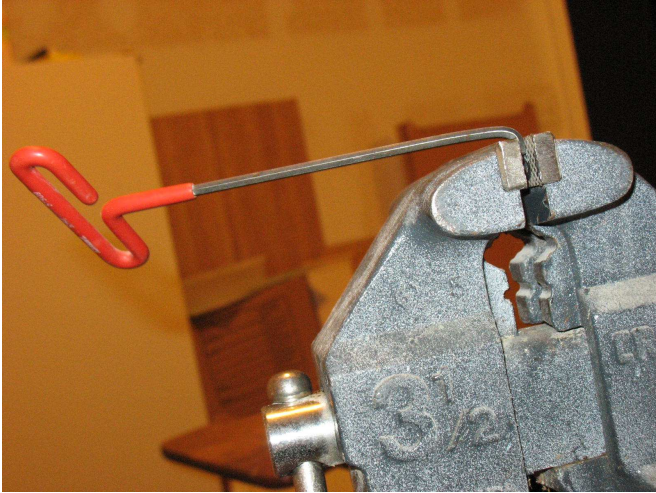

The bent tip is too long to go into the sleeve of the bolt so it will need to be ground using your bench grinder to measure ~ .320 long for the 7/64" hex (3/8" bolts), ~.450 long for the 9/64" hex (1/2" bolt) from the back side of the hex.

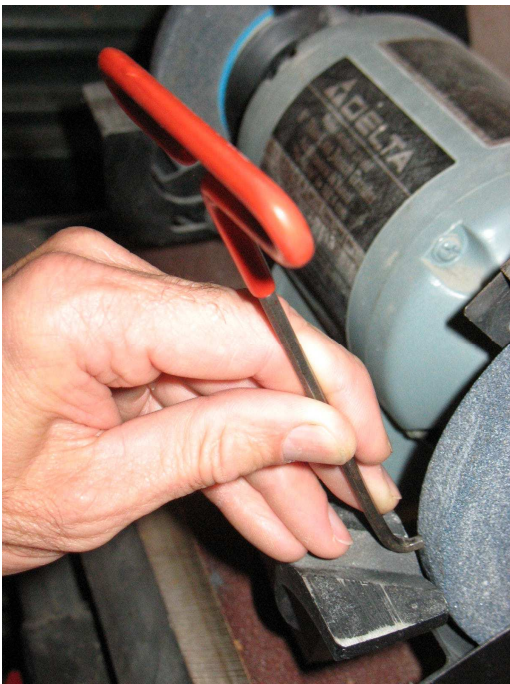



The objective here is when the hex wrench is put in the sleeve and the tip is placed in the triangular hole of the sleeve that the wrench will be a tight fit with the opposite side of the sleeve so the wrench tip will not pop out of the sleeve when you pull on the wrench handle.

This has only proved to work on newly installed bolts. The steel bolts that have been rusted in place for 20 years are just too tight to be moved with the hook tool. The tool is still useful if the end is magnetic and when a sleeve is loose it can be hooked then pulled out of the hole.

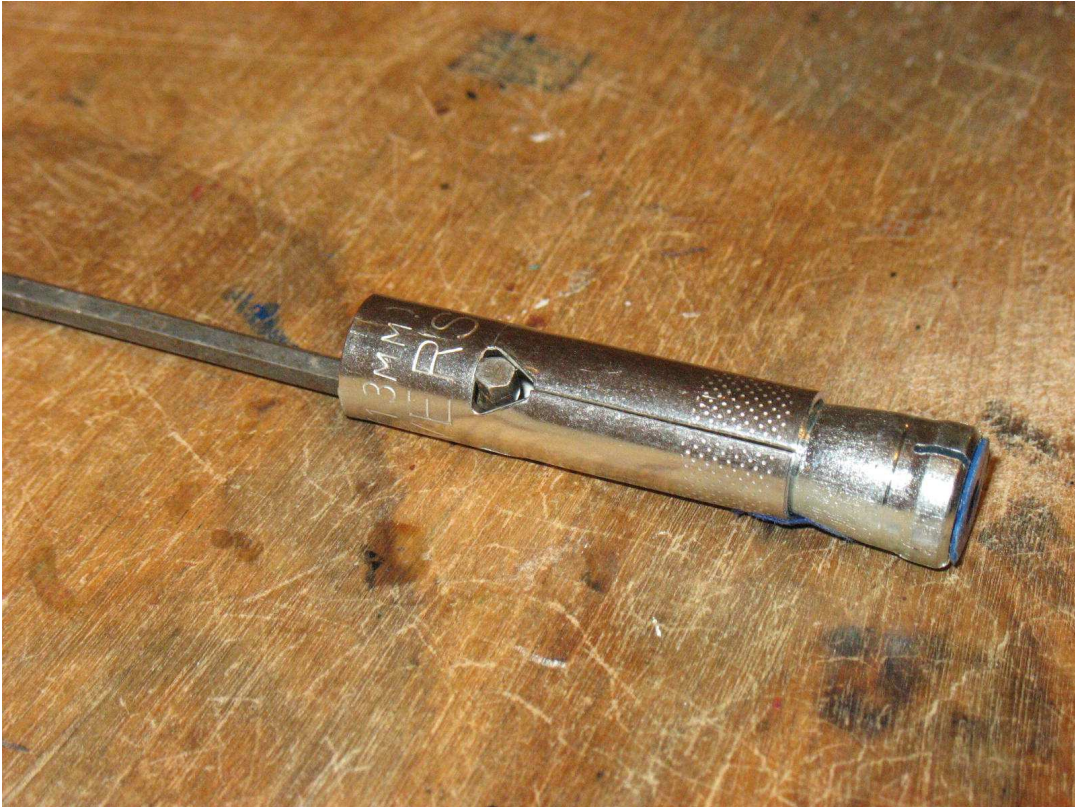
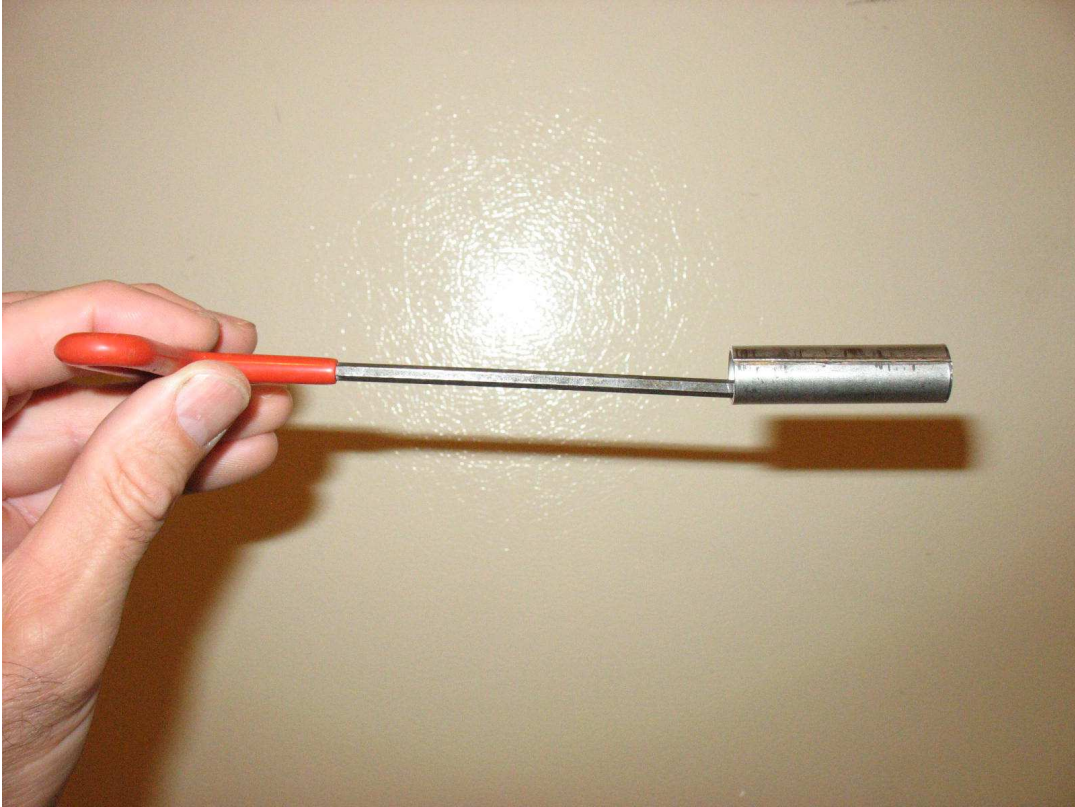

T-hex handle engaged into triangular hole of expansion sleeve

3/8" Sleeve Extraction Tool (required parts)

- A. 9mm x 1 Tap. Doit Best p/n [323985](#)
- B. 9mm X 1 Die. Doit Best p/n [323764](#)
- C. 1) 1/2-20UNF x 4 inch long, full thread, Grade 8 Hex. Hd. Cap Screw.
McMaster Carr p/n [92620A752](#)
- D. 1) 1/2-20UNF x 1 3/4" Coupling nut, Grade 5. McMaster Carr p/n [90977A034](#)
- E. 1) 1/2 inch I.D. X 1" long spacer. McMaster Carr p/n [92415A465](#)
- F. Machine a .349 dia x 2" long shaft on the end of the 1/2-20UNF bolt then cut a 9mm x 1 thread. See drawing below.

Sleeve Extraction Tool

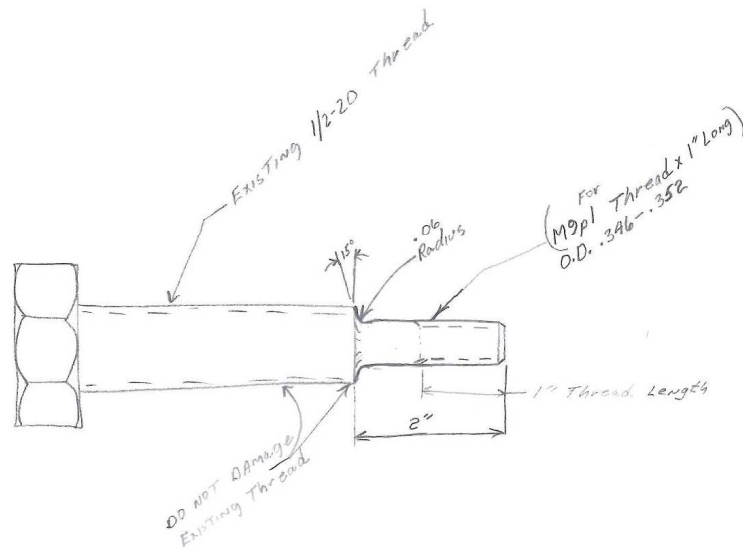

Patent Pending
2012

MTL = 1/2-20 x 4"
Grade 8 Bolt

Gary Bullard
940-300-7212

Extraction tool with 1 inch spacer and 1 ¾ inch long coupling nut.

This tool will work to pull up to 3 ½ inch long bolts. Replace 1 inch spacer with washer for longer bolts.



1/2" Sleeve Extraction Tool (required parts)

- A. 11mm x 1.5 Tap
- B. 11mm x 1.5 Die
- C. 1) 5/8-18UNF x 4 inch long, full thread, Grade 8 Hex. Hd. Cap Screw.
- D. 1) 5/8-18UNF Coupling nut, Grade 5.
- E. 1) 5/8 inch I.D. X 2" long spacer.
- F. Machine a .425-.420 dia x 2" long shaft on the end of the 5/8-18UNF bolt then cut an 11mm thread. (Reference 3/8" sleeve extraction drawing above.)

Need image of tool

Powers™ 5 Piece Bolt Removal Process

Understand, this whole process is out the window if the bolt breaks or won't release from the expansion cone. Then the process would be to drill the bolt out with a twist drill (I have not been successful). If the bolt spins in the hole then use a punch to expand the bolt against the walls of the hole and try to drill again.

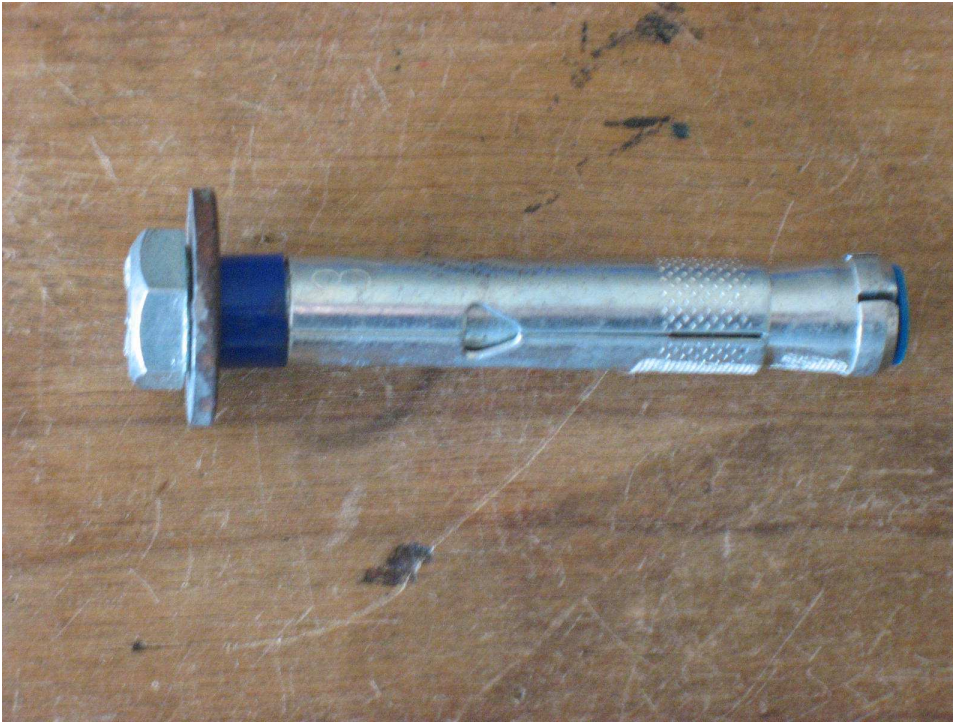

Powers™ 5 piece bolt

- A. Loosen bolt, (I like to use a torque wrench so I know before I reach the bolts limit and don't break the bolt in the hole) count how many turns before the bolt comes out of the threaded expansion cone. I do this for step E, so I know when to stop turning the bolt out so the last thread or two of the expansion cone does not get damaged from striking the bolt with the hammer.

- B. Remove hanger. (Gives more space under the bolt head to help drive the expansion cone out of the expansion sleeve.)



- C. Blow the rust out of the hole.
D. Reinstall bolt
E. Loosen bolt two turns.
F. Strike bolt head with the hammer to drive the expansion cone out of the expansion sleeve.



- G. Repeat E and F until there are no less than two turns of the bolt left in the expansion cone.
H. Remove the bolt.
I. Place the hex head of the bolt on top of the expansion sleeve in the hole and drive it 1/16" into the hole to break loose the corrosion between the sleeve and the rock.



J. If the bolt is longer than 2" it will have an extension sleeve. Remove extension sleeve using the method below.

K. Using the **Sleeve Extraction Tool**.

a. Tap the sleeve 5 turns deep using the 9mm tap.

A tap with chipped cutting edges is beneficial as it snags and allows the forward/reverse of the tap with resistance helping to rotate the sleeve and permits extraction without using the extraction tool.



b. Blow the chips out of the sleeve.

If the sleeve is loose enough, using the T-Handle may be beneficiary for pulling the sleeve out of the hole. Insert the T-handle into the expansion sleeve, feeling for the triangle cut out. See image T-handle engaged into triangular hole of expansion sleeve.

- c. Turn the sleeve extraction tool into the sleeve ~5 turns or until you have good thread engagement inside the sleeve.



- d. Using a box end wrench on the bolt hex and not allowing the bolt to turn, use a wrench to turn the coupling nut clockwise to pull the sleeve out of the hole.





- L. Once the expansion sleeve is out of the hole, brush the rust from the hole and blow out the hole.
If you are extracting the second piece of a 3 ½" long Rawls™ bolt, replace the 1 inch spacer with the washer from the bolt so the extraction tool can reach the expansion sleeve.
- M. Engage the Expansion Cone Extraction Tool by threading the coupling nut back towards the hex of the screw about 2 ½ inches then place the washer from the bolt you extracted on the working side of the Cone Extraction Tool.





- N. Slide the Cone Extraction Tool into the hole and get maximum thread engagement with the expansion cone (finger tighten only).
- O. Use a wrench on the hex head of the bolt if necessary so it does not turn. Turn the coupling nut clockwise will extracting the expansion cone. (If the extraction process gets difficult, unscrew the tool, use the original bolt to move the cone back into the hole about 1/8 inch then blow and or brush the rust out of the hole again).
- P. Reengage the cone extraction tool and thread the cone all the way out of the hole.
- Q. Brush and blow the hole.
- R. Replace with a new SS bolt of the same length or longer and install a Powers™ SS bolt and a SS hanger.



Rawls Bolt markings from the past. Now mfg. By Powers™.

Removing Split Shank Button Head Bolts



This process has been documented in several locations. The basic process is to use a piton with a 5/16" slot milled lengthwise in the piton. Then hammer this under the hanger to wedge the bolt out of the hole. You might need 4 pitons total. If you were to get the stud out about 1/4 inch you could then use a custom adapter on the hydraulic press to pull it out.

Removing Split Shank Stud Bolts

By just seeing the thread stick out of the rock it is really unclear as to what bolt is in the hole, it could be a Fixe Wedge (10mm thread), Powers Powerstud bolt or split shank stud.

Use the adapter (**see image below**) and a 1" coupling nut with a thick washer between the coupling nut and the rock which keeps pressure on the rock so it doesn't blow out (sparge).

- A) Using a torque wrench set at 60 ft./lbs. loosen the nut ~1/2 turn. Strike the Stud to drive it into the hole 1/16", breaking the rust bond with the rock.
- B) Remove the nut and hanger.
- C) Place a heavy duty washer with a 7/16 hole over the stud.
- D) Thread the adapter/coupling nut Assy. on the stud until tight.
- E) Holding the bolt head from rotation turn the coupling nut CW as if removing the nut and pressing against the rock.
- F) Continue until the bolt is extracted.
- G) Clean the hole, check the depth and install a new 3/8" Powers bolt and hanger.

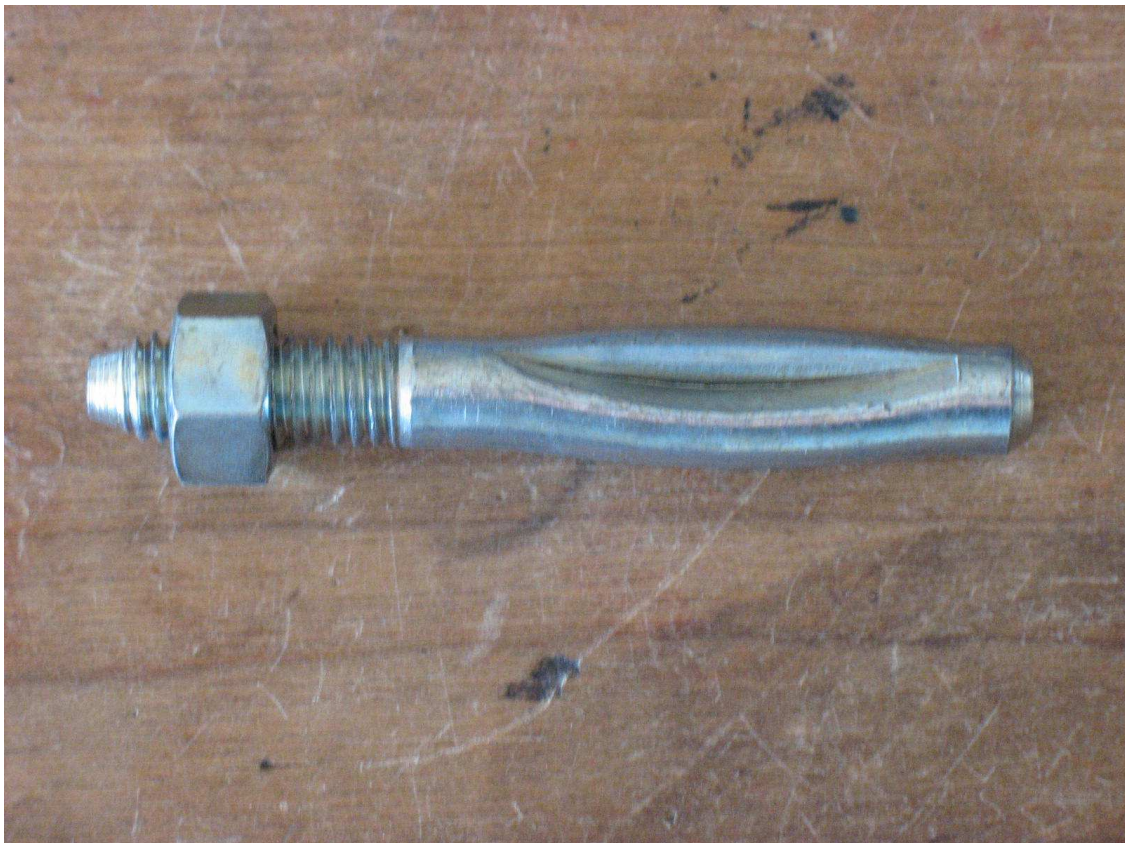



McMaster-Carr #90983A240

Adapter Drawing

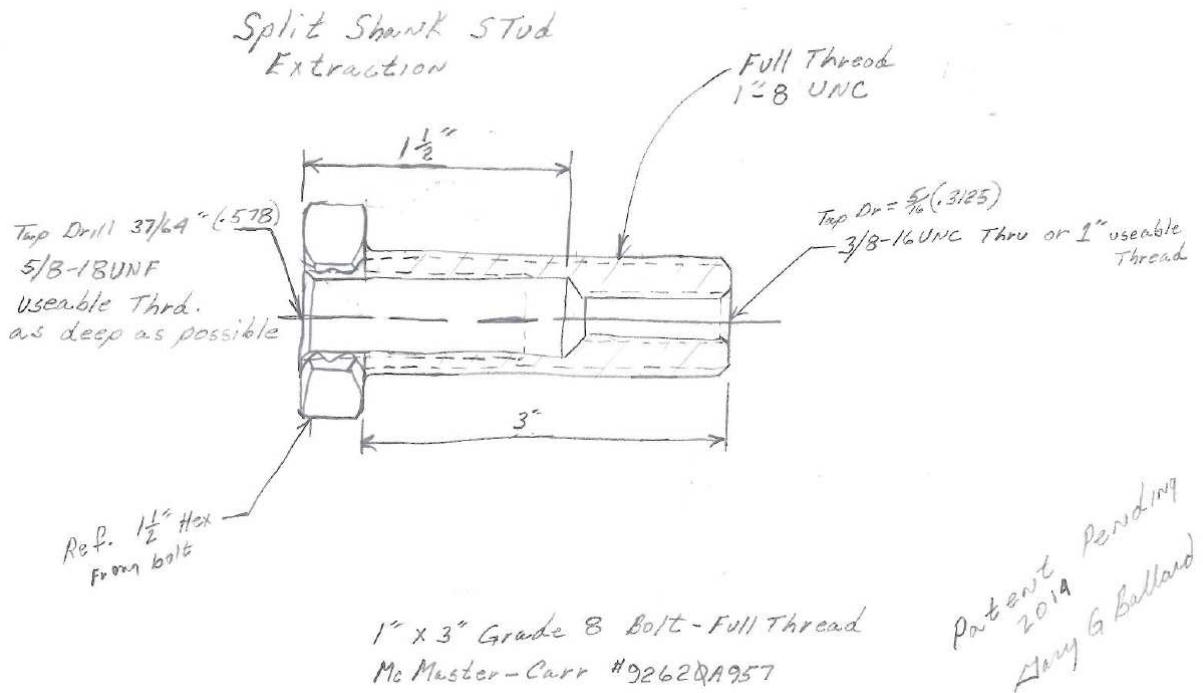
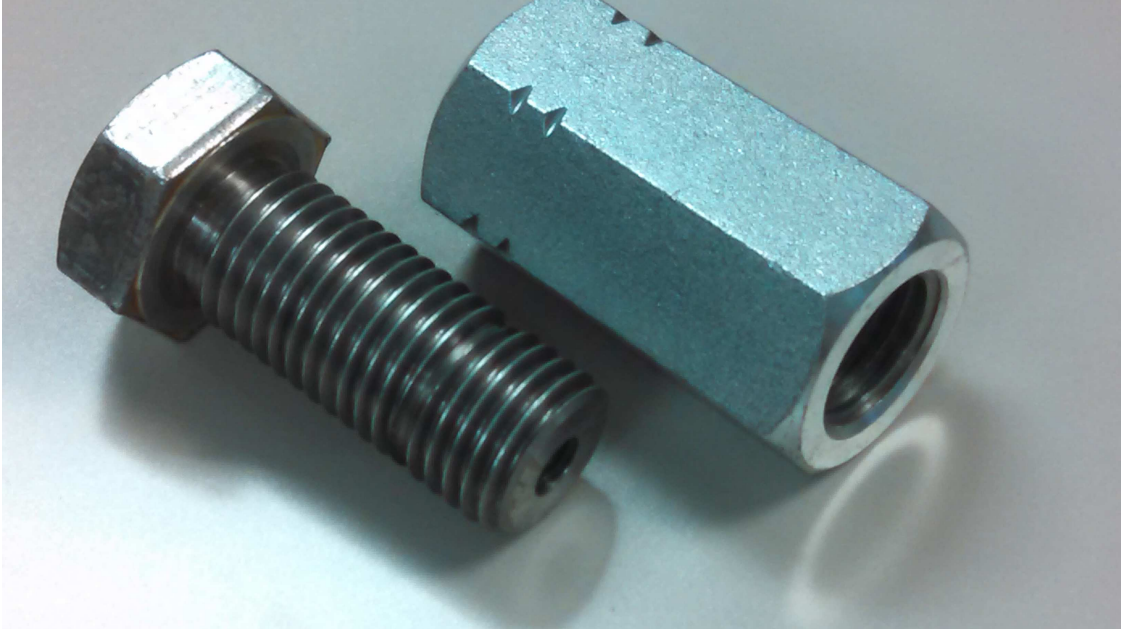

IMAGE OF EXTRACTION TOOL



This method has proven to blow out the rock (sparge).

Use the adapter tool with a 2# or 5# slide hammer to extract the bolt from the hole.



The 2# slide hammer may need a different size thread on the adapter side or manufactures threads may vary, so get your slide hammer first then build the adapter. Various size adapters will be needed for 3/8", 5/16" or 1/4" split shank studs.

Removing a Metolious™ Bolt (SS with o-ring and brass expansion cone shown)



Similar to the process for Powers™ 5 piece bolt.

Fixe™ Triplex 3-piece bolt removal



- A. Remove nut and hanger.
- B. Put nut back on stud so the stud slightly protrudes out of the nut. (This is a safety precaution so the stud does not get driven into the hole and cannot be extracted.)
- C. Tap on the stud with a hammer to drive the stud deeper into the hole, tap on the stud until the nut touches the shoulder of the sleeve. (Sometimes the hole may not be deep enough to achieve this goal but should have been deep enough to allow the sleeve to collapse to allow extraction.)
- D. Leave the nut in place as a support for the sleeves shoulder when extracting.
- E. Use a forked piton or similar forked device to wedge between the rock and the sleeve shoulder to force the sleeve to break loose. Once the sleeve has broken loose the nut can be removed and the sleeve continued to be removed by the wedge method.
 - a. The sleeve and stud as one unit can continue to be removed in this manner if additional spacers are put between the rock and the wedge under the shoulder of the sleeve.
- F. Once the sleeve is out of the hole then either use a Funkness device to pull the stud out of the hole or use a 12 mm nut with spacers under the nut to slowly screw the stud out. You will need to back the nut to the end of the stud, add additional spacers each time you run out of threads on the stud. There are other options similar to the cone extraction tool that can be used to extract the stud.

Wedge bolt removal

There is not any easy way to extract these bolts. Slide hammer method will blow the rock out. Drilling with a hollow core drill has shown some success.

Spin method for removing this type of bolt

www.youtube.com/embed/ewqSojyT3vM?feature=oembed

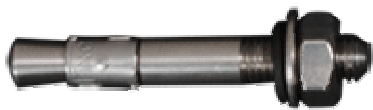

I highly recommend not using this type of bolt.

Powers™ Powerstud™ removal

This is going to have the same challenges as the wedge bolt.

Spin method for removing this type of bolt

www.youtube.com/embed/ewqSojyT3vM?feature=oembed

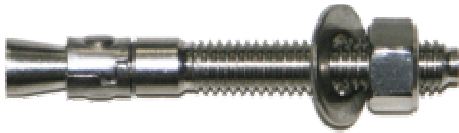

I highly recommend not using this type of bolt.

Mammut™ Ring Bolt



Process (not proven as of 15 Dec 1014)

- A) Remove ring, via grinder, hacksaw or bolt cutter.
- B) Drill $3/16$ " dia. hole down the center of the pin ~ 1.35 inches deep to gain access to the expansion pin.
- C) Drill $25/64$ " (.3906") or 10mm hole to the same depth.
- D) Tap $7/16$ -20 full depth
- E) Thread special $7/16$ -20 grade 8 bolt into hole. **(See Drawing below)**
- F) Use torque wrench. To not break the bolt, do not exceed 80 ft/lbs of force.
- G) Tighten the bolt, once the expansion cone breaks free continue to turn the bolt to extract the Mammut™ bolt.
- H) Pull the expansion cone out of the hole with a magnet, wire, etc.
- I) You are left with a $5/8$ " hole. Drill appropriate size hole to the correct depth for a glue-in bolt.

See Tool image on next page

Mammut Ring Bolt Extraction

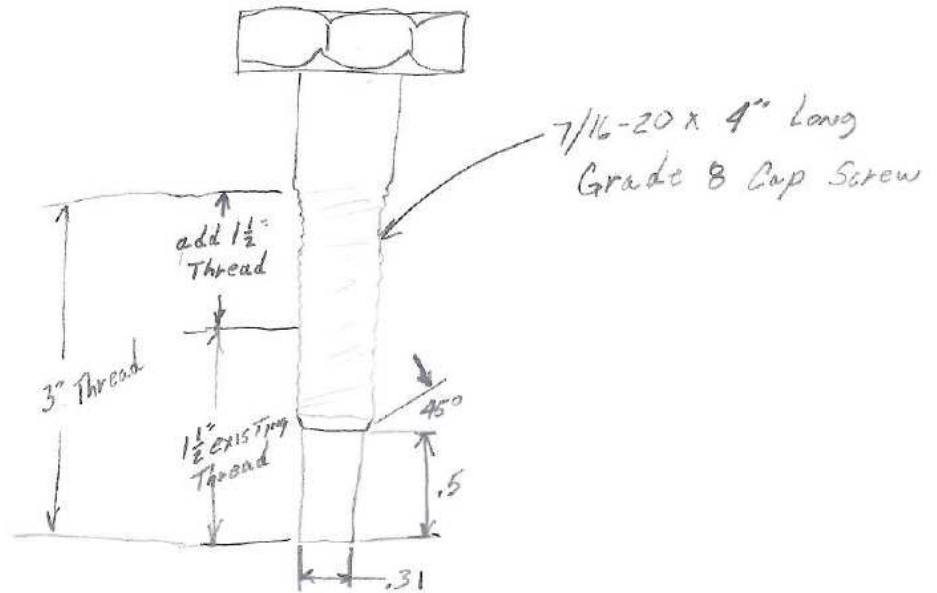

IMAGE OF EXTRACTION TOOL



Good luck with all your bolt extraction projects. Hopefully the climbing community will use Stainless Steel bolts in all of their future placements.

Gary Ballard
gballard60@juno.com